

luma ring light

#7637 LUMA RING LIGHT

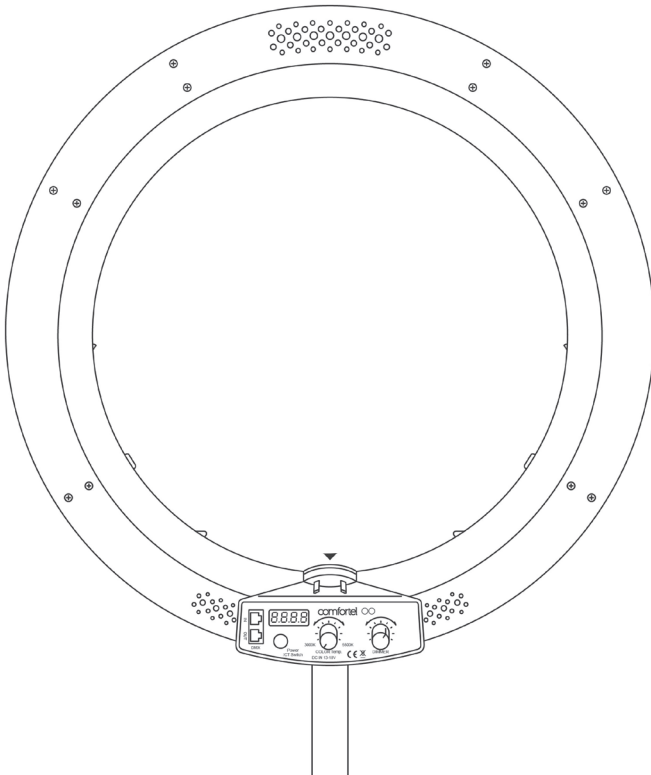

IMPORTANT PLEASE READ THESE SAFETY INSTRUCTIONS

GENERAL SAFETY

1. Read carefully and keep these instructions in a safe place.
2. Use this product only for its intended function and do not use attachments not recommended by the manufacturer.
3. Do not use outdoors.

PRECAUTIONS

1. Be sure to look over the guide and familiar with its features before using.
2. Avoid unplugging the power by pulling the power cord and do not touch the power cord with wet hands.
3. Never attempt to insert any metal objects into the cooling holes of the ring light.
4. Avoid moving the ring light by pulling the power cord
5. Do not expose ring light to water or in a moisture location.
6. All maintenance to be carried out by a suitably qualified trades person.

ELECTRICAL APPLIANCES

1. DO NOT allow children to operate in this product.
2. Turn the power off and remove the plug when not in use or when cleaning.
3. Do not let the power cord get damaged in any way.
4. Keep the power cord away from heat sources.
5. Do not use an extension cord unless the cord complies with local electrical safety standards.
6. Periodically inspect the power cord for signs of damage.
7. Do not operate any electrical item with a damaged power cord.



Water poses a serious risk even when device is switched off, do not leave device connected to power supply after use.

GET STARTED

LUMA RING LIGHT

Professional 48cm Ring Light with Temperature Control

Included in this box

- 1 x Comfortel Luma 48cm Ring Light
- 1 x Smartphone Holder
- 1 x Adjustable Tripod Stand with Gooseneck Attachment
- 1 x Click on Mirror
- 1 x Power Adapter
- 1 x Carry Bag

TECHNICAL SPECIFICATIONS

Size (HxWxD)	48cmx48cmx4.6cm
Power Range	60W
Illumination	>6000LM
Ra	>95
Colour Temperature	Seamless from 3200k to 5600k
Operation Voltage	240V/50-60Hz
Brightness Dimmable	From 10% to 100%
Net Weight	1.6KG

INSTALLATION & ASSEMBLY

SETTING UP THE TRIPOD

1. Bend the legs backwards as shown in the image below to open the tripod



2. Extend the legs. Open the latches that release the legs and extend the sections. Be sure the legs are secure and check the level on the tripod.
3. Attach Goose Neck to top of tripod
4. Once tripod is level and steady attach the Luma Ring Light.

INSTALLATION & ASSEMBLY

HOTSHOE SMARTPHONE BRACKET

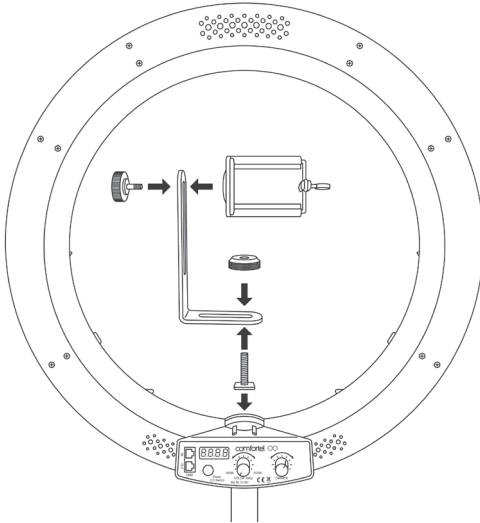

FUNCTIONS

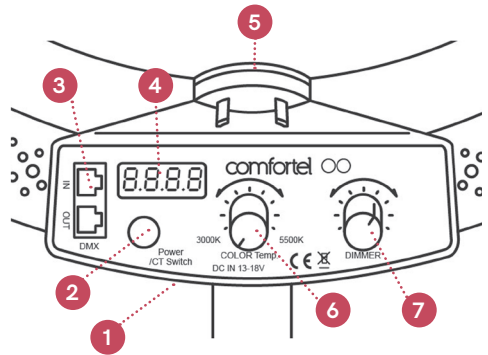

PARTS

1. DC Power Input
2. Power switch/CT Switch/Function
3. RJ45 (for DMX or Remote)
4. LED Display (Colour Temp/Brightness/Function)
5. Hot shoe Smart phone Bracket
6. Colour temperature
7. Brightness

OPERATION

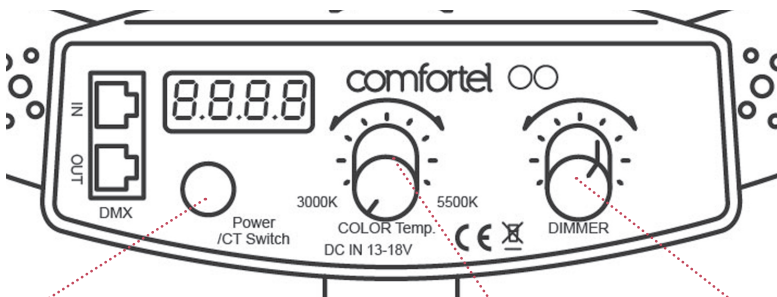

POWER ON Press the button to turn the Ring light on
CT SWITCH Press the button to get a quick setting of 3000k/4250k/5500k in turn
POWER OFF Keep pressing the Power button for 3 seconds until LED display shows 'OFF'
DMX ADDR. Keep pressing the button for next 3 seconds while LED display shows OFF
DELAYED SHUT DOWN Rotate the knob 7 to set the exact time for shut down while LED display shows 'OFF'

ADJUST TEMPERATURE OF LIGHT
Turn Colour Temp Knob to set the colour temperature from warm 3000k to cool 5500.

ADJUST BRIGHTNESS OF LIGHT
Turn Dimming Knob to set the brightness from low to high.



**CAUTION: DO NOT USE LIGHT IF FLEXIBLE CORD IS DAMAGED
ANY REPAIRS TO LIGHT MUST BE CONDUCTED BY A QUALIFIED ELECTRICIAN.**

WARRANTY PERIOD

PERIOD AND DESCRIPTION	PRODUCTS
12 MONTHS PARTS & LABOR	All products
2 YEARS PARTS ONLY	All products excluding small electrical appliances
3 YEARS PARTS ONLY	All Linak electric actuators
5 YEARS PARTS ONLY	Taps cartridge, Ceramic basins

TERMS AND CONDITIONS

For more information about our terms and conditions including warranty, please refer to our website.

CLEANING

BEFORE CLEANING MAKE SURE THE LIGHT IS DISCONNECTED FROM THE ELECTRICAL SUPPLY

The unit requires no special maintenance. If it becomes heavily soiled it can be wiped with a damp cloth containing a mild soap solution. Do not use large quantities of liquid as it may enter shade housing and affect electrical safety.

DO NOT USE ALCOHOL, SOLVENTS OR ABRASIVE CLEANERS, AS THEY WILL DAMAGE THE PLASTIC HOUSING.

MAINTENANCE

A periodic inspection of all components and fasteners should be made to ensure that your product is structurally intact and functioning properly.

Damaged and broken parts should be replaced and loose fasteners tightened.

All maintenance to be carried out by a suitably qualified tradesperson.

comfortel

comfortel.com.au

PRODUCT CODE

#7637 LUMA RING LIGHT

Revision Date: 28.06.2018

©Comfortel Furniture 1997-2018. All rights are reserved. No part of this document may be photocopied, reproduced or translated to another language without written consent of Comfortel Furniture Pty Ltd.

The information contained in this document is subject to change without notice and should not be construed as a commitment by Comfortel Furniture Pty Ltd.

Comfortel Furniture Pty Ltd. assumes no responsibility for any errors that may appear in this document nor does it make expressed or implied warranty of any kind with regard to this material, including, but not limited to, the implied warranties of merchantability and fitness for a particular purpose.

Comfortel Furniture Pty Ltd. shall not be liable for incidental or consequential damages in connection with or arising out of the use of this document and the program material.

PLEASE RETAIN THIS INFORMATION FOR FUTURE REFERENCE.

For more information about our products and services, contact us at comfortel.com.au

PURCHASE DATE

INVOICE NUMBER

NOTE YOUR PURCHASE DATE & INVOICE NUMBER FOR FUTURE REFERENCE